



Castello Luxury Baths



TECHNICAL SPECIFICATIONS

Est. Weight: 100kg *Products are made from an advanced composite stone*

Petit freestanding Bath

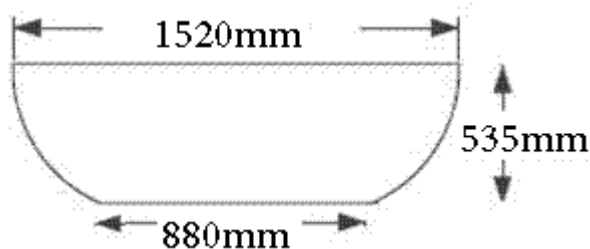

Side

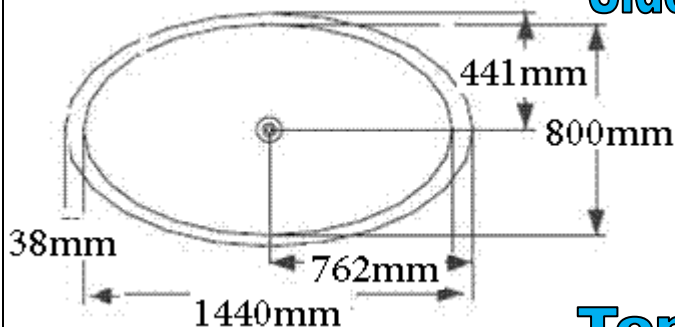

Top

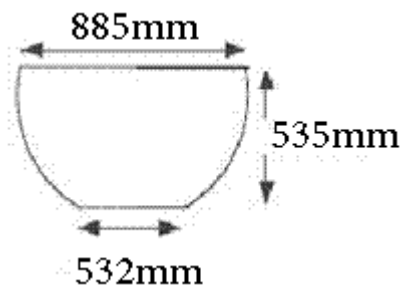

Front

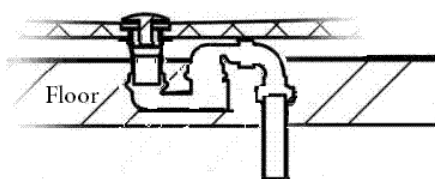

Waste

Waste and P-trap below floor level

Unique Features include:

- ✓ Unique "ECO-SMART" design uses less water to fill
- ✓ High water heat retention
- ✓ Ergonomic design for true comfort
- ✓ Scratch resistant
- ✓ Fire retardant
- ✓ Mould and mildew resistant
- ✓ Bacteria resistant
- ✓ Non-porous
- ✓ Stain resistant and easy to clean
- ✓ Organic appearance and feel of stone

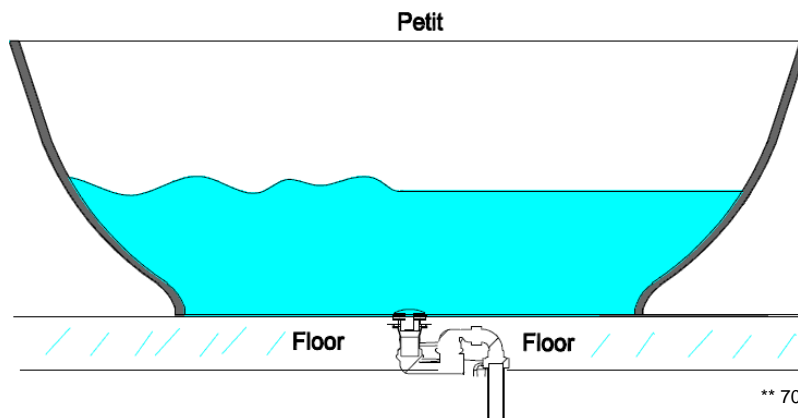
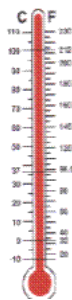

** 70 litres displacement on average.