



Castello Luxury Baths



TECHNICAL SPECIFICATIONS

Est. Weight: 136kg *Products are made from an advanced composite stone*.

Imperia Bath

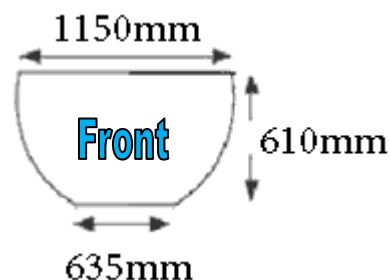
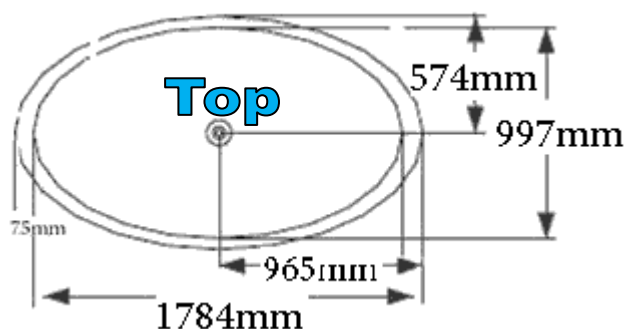
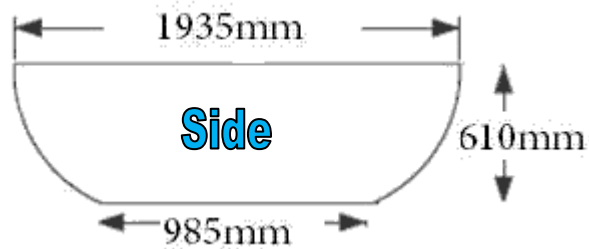

Waste and P - trap above floor level

Waste

Unique Features include:

- ✓ Unique "ECO-SMART" design uses less water to fill
- ✓ High water heat retention
- ✓ Ergonomic design for true comfort
- ✓ Scratch resistant
- ✓ Fire retardant
- ✓ Mould and mildew resistant
- ✓ Bacteria resistant
- ✓ Non-porous
- ✓ Stain resistant and easy to clean
- ✓ Organic appearance and feel of stone

Imperia

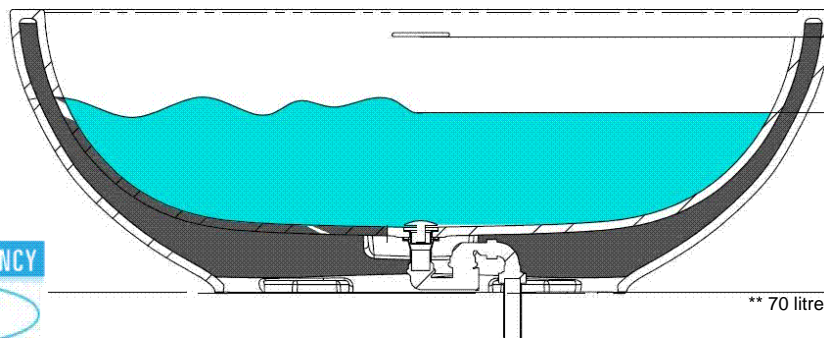
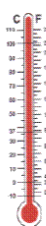

476kg 340Ltr

316kg 180Ltr

136kg 0Ltr

** 70 litres displacement on average.



HIGH EFFICIENCY

