



Castello Luxury Baths



TECHNICAL SPECIFICATIONS

Est. Weight: 130kg *Products are made from an advanced composite stone*

Eco free standing Bath

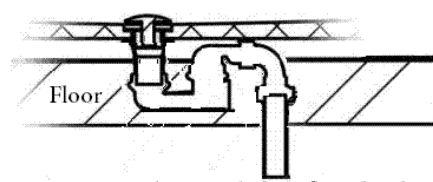
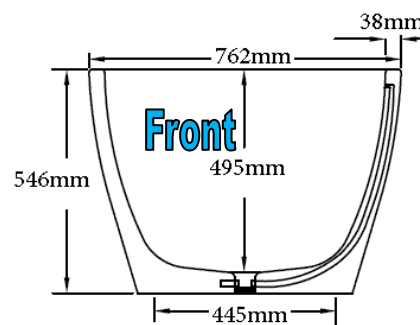
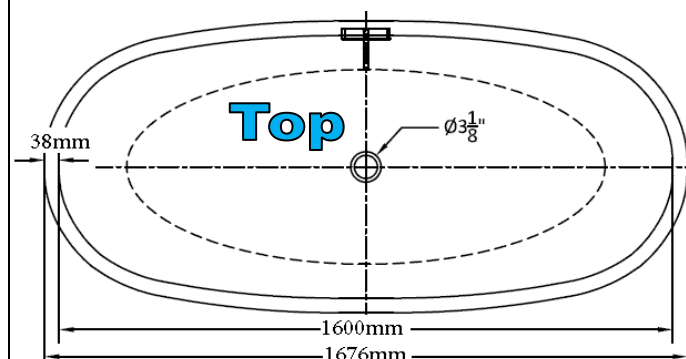
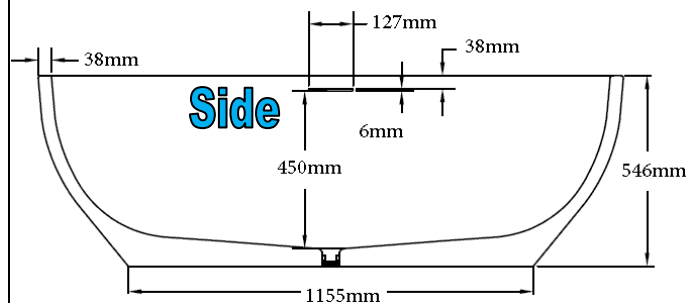

Waste

Waste and P-trap below floor level

Unique Features include:

- ✓ Unique "ECO-SMART" design uses less water to fill
- ✓ High water heat retention
- ✓ Ergonomic design for true comfort
- ✓ Scratch resistant
- ✓ Fire retardant
- ✓ Mould and mildew resistant
- ✓ Bacteria resistant
- ✓ Non-porous
- ✓ Stain resistant and easy to clean
- ✓ Organic appearance and feel of stone

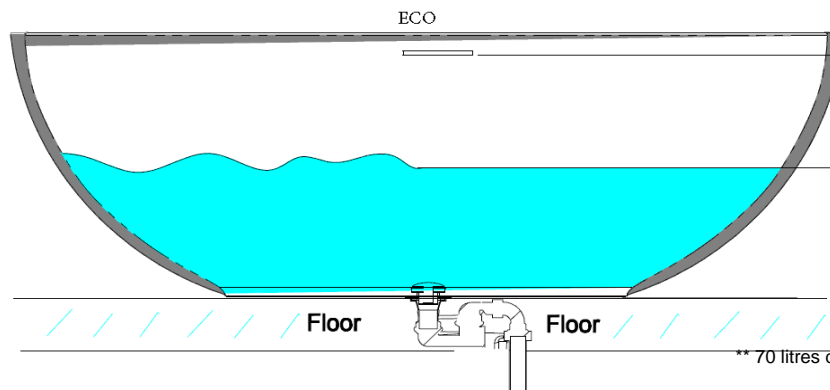
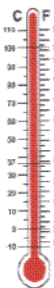

370kg 240Ltr

290kg 160Ltr

130kg 0Ltr



** 70 litres displacement on average.



Castello Luxury Baths: 57 Knowl Piece: Wilbury Way: Hitchin: Hertfordshire: SG4 0TY
www.castellobaths.com www.hotelbaths.co.uk sales@castellobaths.co.uk

