



Castello Luxury Baths



TECHNICAL SPECIFICATIONS

Est. Weight: 116 kg *Products are made from an advanced composite stone*.

Adoni freestanding Bath

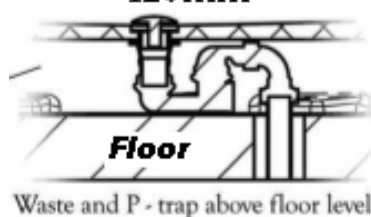
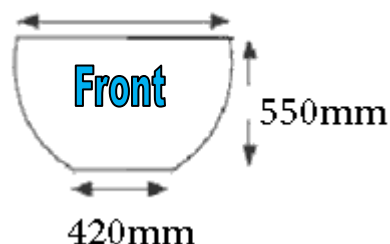
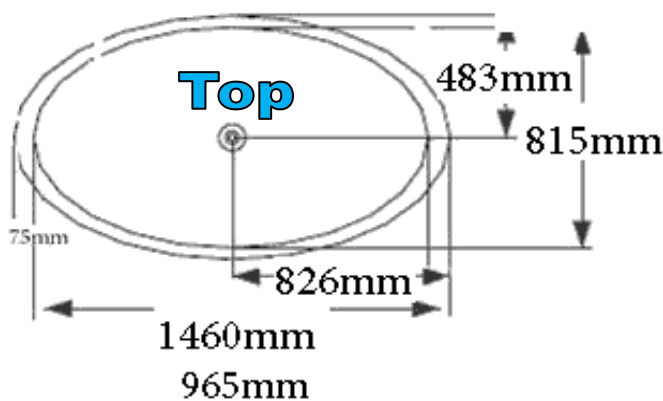
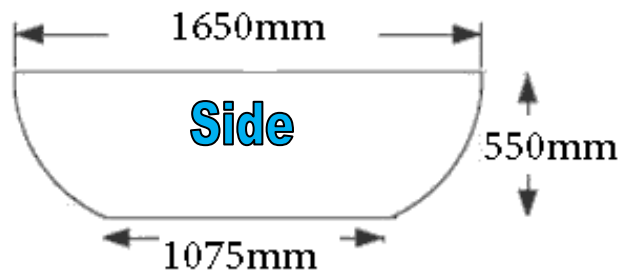

Waste

Unique Features include:

- ✓ Unique "ECO-SMART" design uses less water to fill
- ✓ High water heat retention
- ✓ Ergonomic design for true comfort
- ✓ Scratch resistant
- ✓ Fire retardant
- ✓ Mould and mildew resistant
- ✓ Bacteria resistant
- ✓ Non-porous
- ✓ Stain resistant and easy to clean
- ✓ Organic appearance and feel of stone

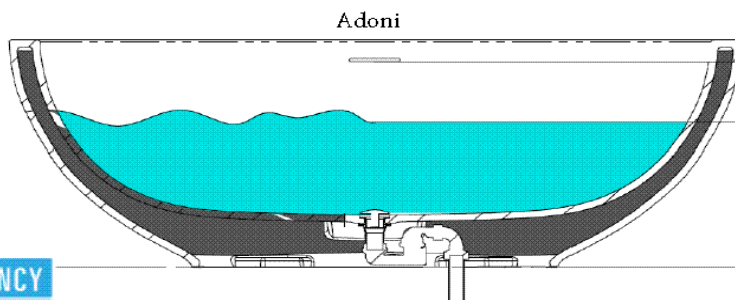
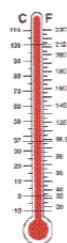

- kg 296kg 180Ltr
- kg 256kg 140Ltr
- kg 116kg 0kg



HIGH EFFICIENCY



70 litres displacement on average.

